

DATA SHEET

S4LFT3161-292

F-THETA
TELECENTRIC - FUSED SILICA
515 - 545 nm



OUTLINE DRAWING

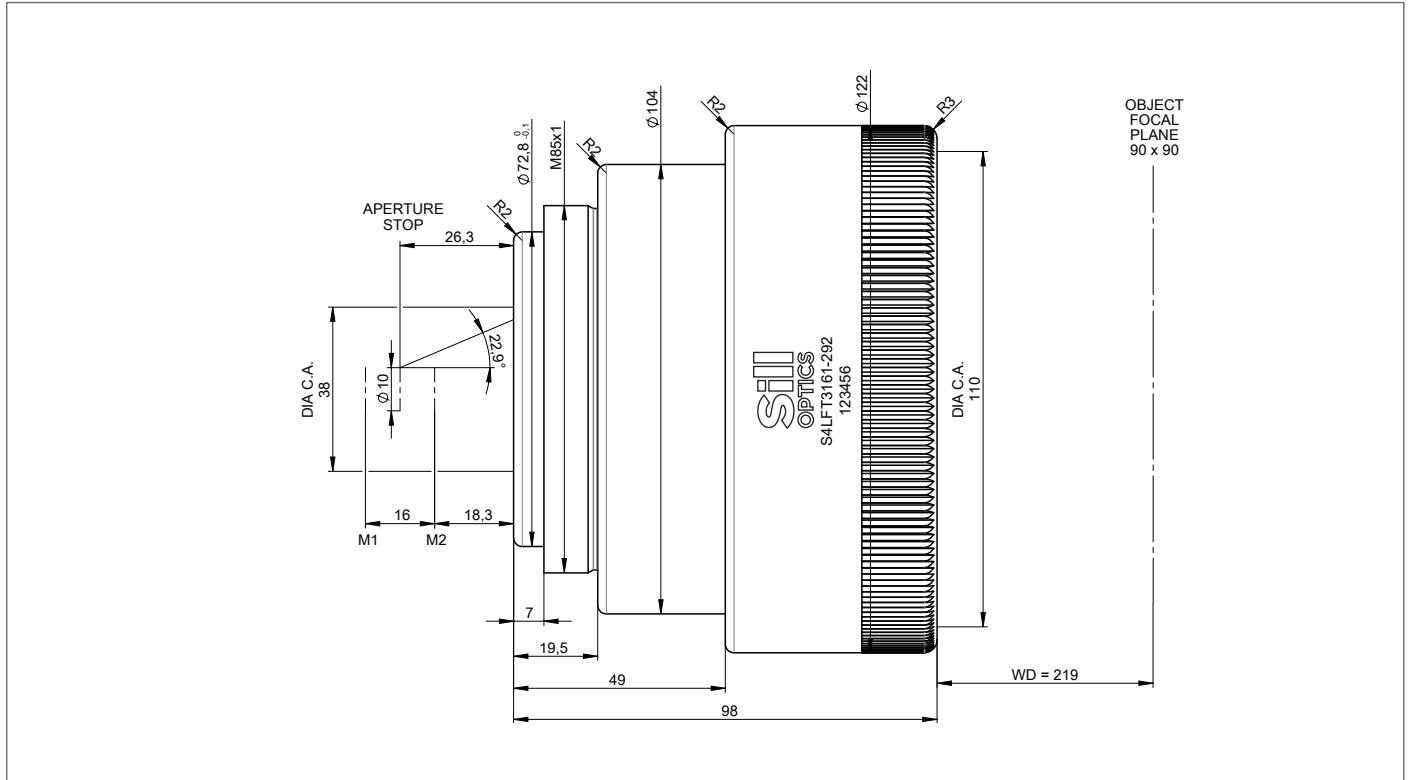

All information contained in this data sheet is for information purposes only and is not binding. The content is subject to change at any time without notification, all information without guarantee. We reserve the right to make constructional changes in the course of product improvement. Copyright © Sill Optics GmbH • All rights reserved

Sill Optics GmbH • Johann-Höllfritsch-Straße 13 • D-90530 Wendelstein • +49 9129 9023-0 • Published: 26.07.2023

DATA SHEET

SPECIFICATIONS

article number	S4LFT3161-292
design wavelength [nm]	532
effective focal length [mm]	163.9
working distance [mm]	219.0
max. entrance beam-Ø [mm]	10.0
aperture stop distance [mm]	26.3
scan area for a 2 mirror system with mirror distance from lens housing for mirror 2 / mirror 1 [mm x mm]	90 x 90 18.3 / 34.3
max. telecentricity error [°]	4.8
total transmission [%]	> 97
absorption [ppm]	not specified
lens material	fused silica
LIDT (coating)	2.5 J/cm ² per 1ns pulse at 50Hz
SP and USP usable	yes
weight [kg]	0.4
cover glass	S4LPG4160-292
cleanliness	not specified

SPOT

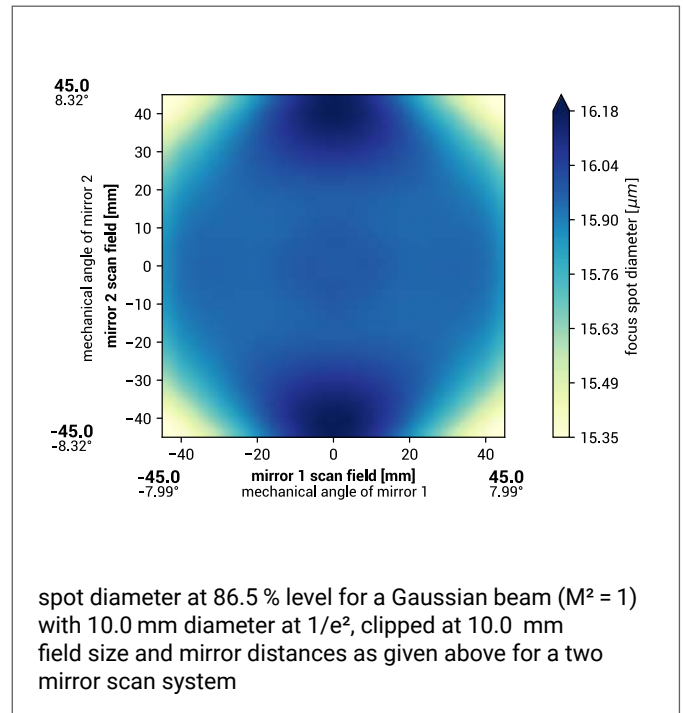

BACK REFLECTION POSITIONS

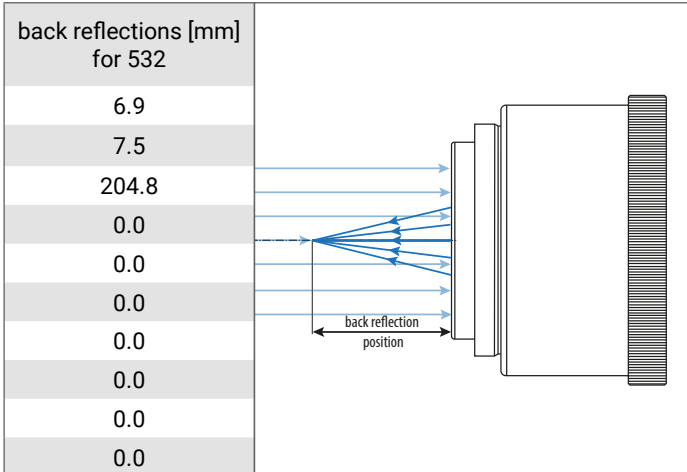

REMARKS

- The stated values are based on a vignetting of less than 1 %.
- Effective focal length and working distance have a tolerance of +/- 1.5 %.
- Absorption tolerance +/- 25 %. Absorption may increase. Correct cleaning establishes original condition.

All information contained in this data sheet is for information purposes only and is not binding. The content is subject to change at any time without notification, all information without guarantee. We reserve the right to make constructional changes in the course of product improvement. Copyright © Sill Optics GmbH • All rights reserved

Sill Optics GmbH • Johann-Höllfritsch-Straße 13 • D-90530 Wendelstein • +49 9129 9023-0 • Published: 26.07.2023